

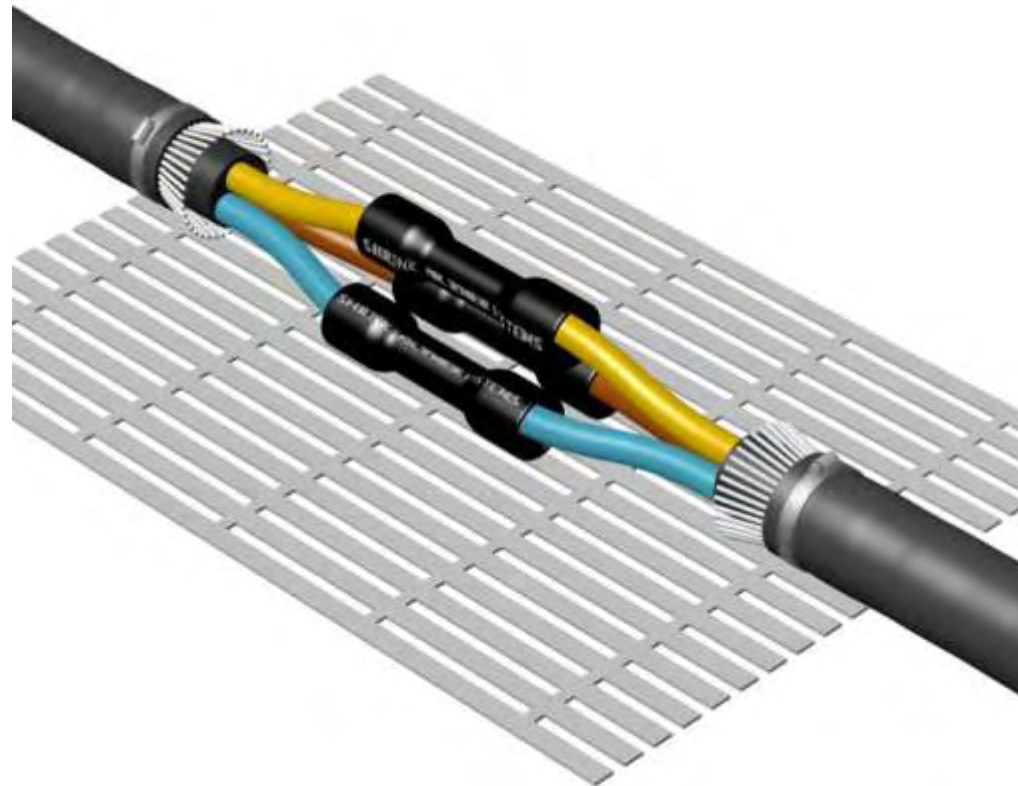

Shrink Polymer Systems

Cable Installation Materials – 24 volts to 36 kV

INSTALLATION INSTRUCTION
HEASHRINK JOINT TO SUIT 3-4 CORE XLPE/SWA/PVC
CABLE 0.6 TO 3.6kV TYPE: SPA



DATE OF ISSUE: - 29.10.08

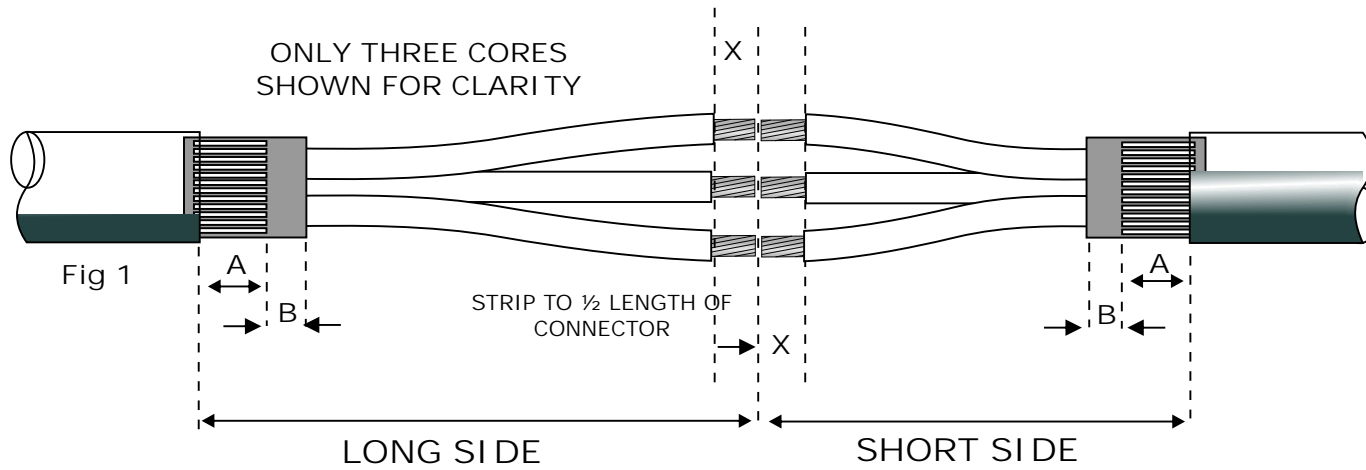

1. Ensure that the Cables overlap and prepare as above using the dimensions given in Table 1 below.
2. Slide the Outer Shrink Tube, Armour Clamps and Copper Sock (If used) over the Cable end/s.

CONDUCTOR SIZE (mm ²)	LONG SIDE (mm)	SHORT SIDE (mm)	BEDDING B (mm)	ARMOUR A (mm)	X
1.5-6	150	90	10	30	HALF CONNECTOR LENGTH
10-16	170	135	15	35	
25-50	215	135	20	45	
70-95	300	200	20	50	
120-185	400	300	20	60	
240-400	530	390	30	75	

TABLE 1

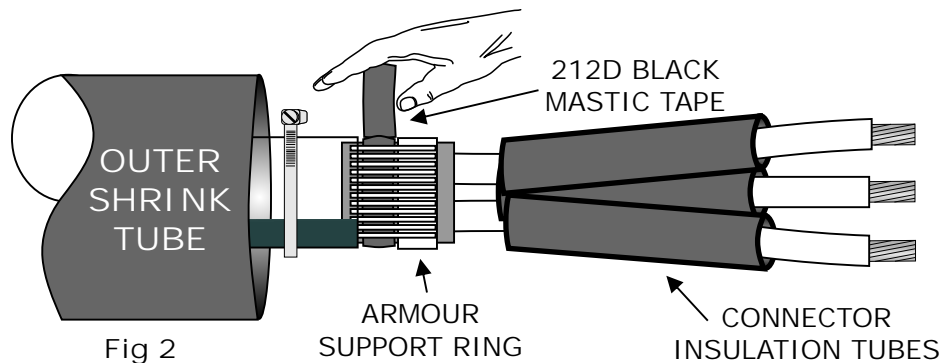

3. Bend back the Armour Wires and apply 212D Black Mastic Tape around the Cable Bedding. Fit the Armour Support Ring towards the end of the Bedding. Press the Armour Wires into the Tape before applying more Black Tape as shown in Fig 2.

Position the Core Tubes down the longer Cores
 Note: - If 3 and 1/2 Core Cable being used, ensure any smaller Connector Insulation Tube is positioned on the smaller of the Cores.

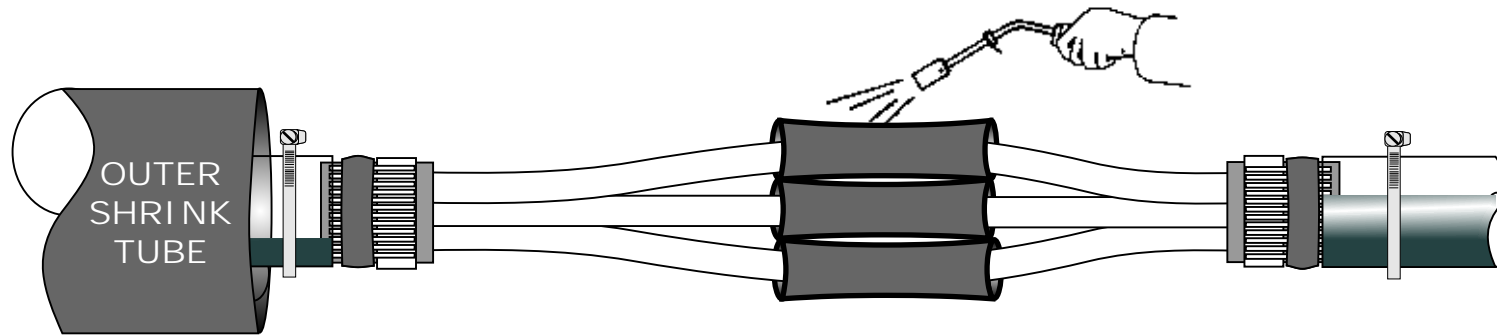

Fig 3

4. Expose the Conductors to half the length of the Connectors and fit using a suitable Crimp tool.
 Note:- Mechanical Shearbolt Connectors can be used, but user should advise as Insulation Tubes will need to be increased in size.

5. Position the Tubes centrally over the Connectors and shrink from the centre to one end at a time. Keep the flame on the move to ensure an even wall thickness. Sealants will be visible at Tube ends once fully shrunk.

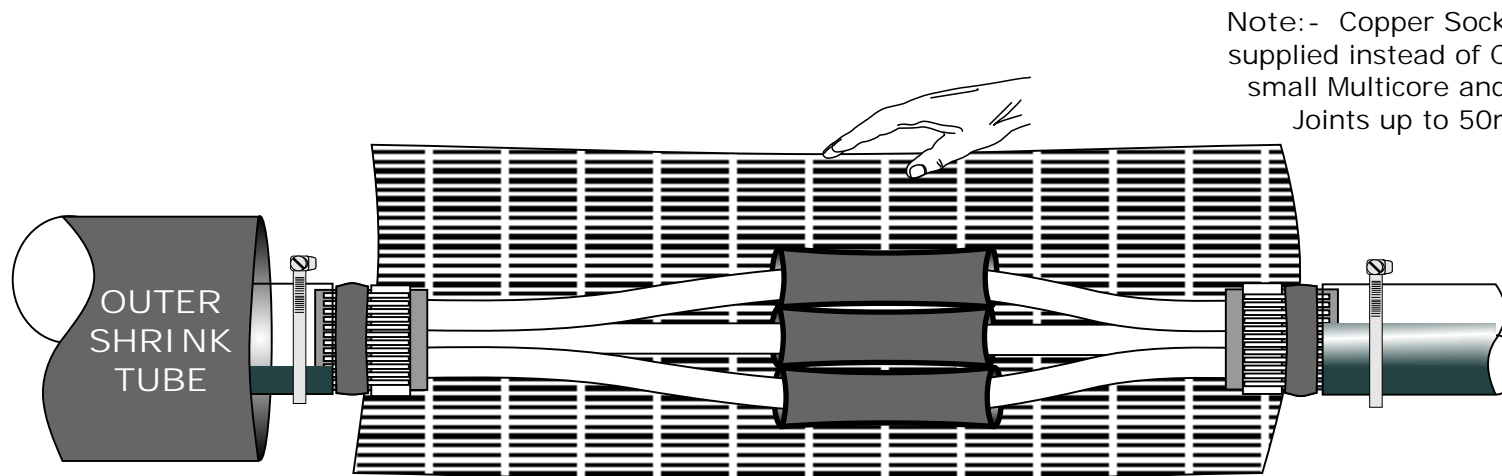

Fig 4

Note:- Copper Sock/Mesh is supplied instead of Cages for small Multicore and Power Joints up to 50mm²

6. Wrap the Armour Cage around the joint gap and secure to the Armours at both sides with the Armour Clamps provided (Roll Springs if Copper Sock). Note:- User may need to apply Tape to the Cores to keep the joint profile down, particularly in the case of core crossing.

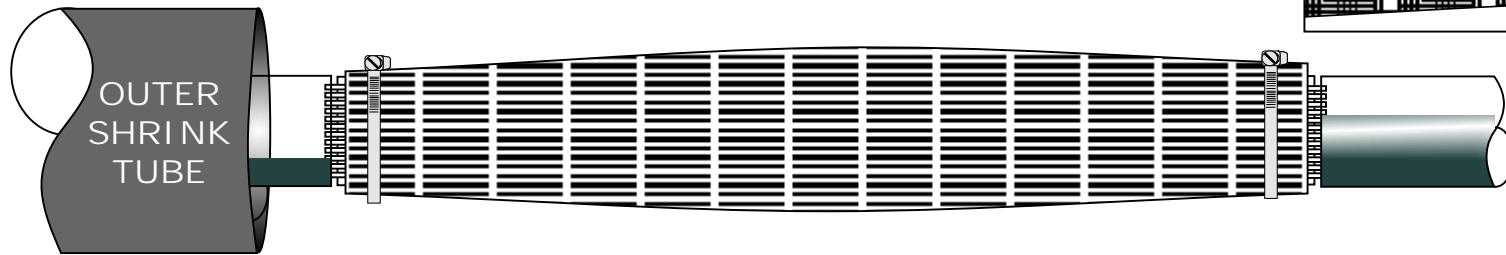

Fig 6

Figure 5 shows Copper Sock secured to Armours With Roll Springs

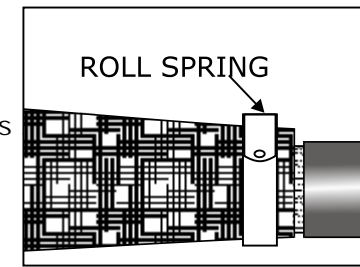

Fig 5

7. Tape over any sharp points including Clamp Buckles.

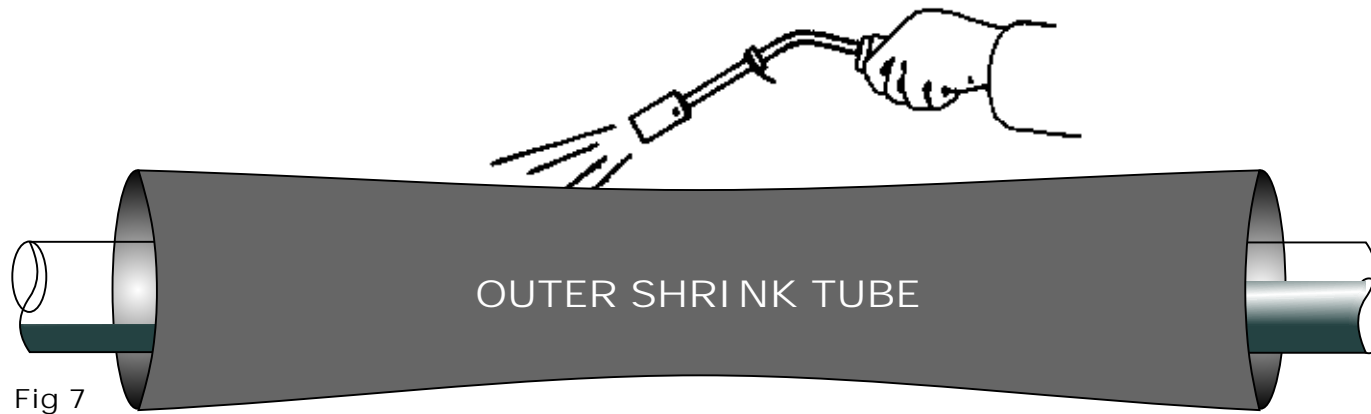

Fig 7

8. De-grease the Cable Sheaths with the Tissues provided. Centralise the Tube and shrink from the centre to one end at a time. Keep the flame on the move all around the Tube to ensure an even wall thickness.

9. Allow the completed Joint to cool before applying any mechanical strain.

IMPORTANT NOTICE TO PURCHASER: - Sellers and Manufacture's only obligation shall be to replace such quantity of the product proved to be defective. Neither the Seller nor Manufacturer shall be liable for any injury, loss or damage, direct or consequential, arising out of the use or inability to use the product. Before using, User shall determine the suitability of the product for his or her intended use and User assumes all risk and liability whatsoever in connection therewith.

