

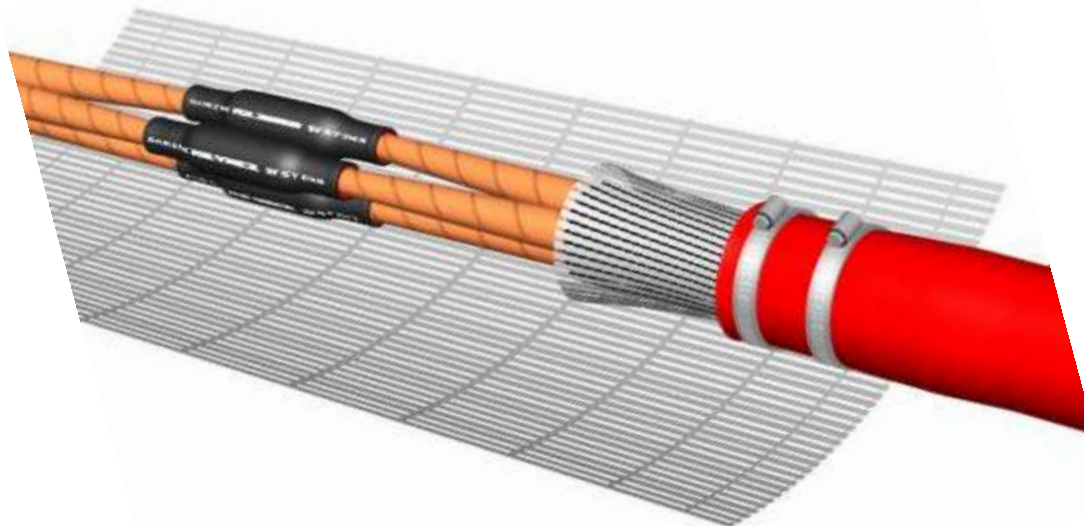

# Shrink Polymer Systems

Cable Installation Materials – 24 volts to 36 kV

## INSTALLATION INSTRUCTION HEASHRINK JOINT TO SUIT 3 CORE 33kV POLYMERIC CABLE TYPE SPAJ 36X



- THESE INSTRUCTIONS SHOULD BE FOLLOWED BY A TRAINED COMPETENT FITTER
- A PROPANE GAS TORCH IS THE PREFERRED METHOD FOR SHRINKING THESE MATERIALS
- ENSURE THAT THE MATERIALS ARE KEPT CLEAN AND DRY AND ARE FREE FROM DUST, SAND AND GREASE
- PLEASE CALL SHRINK POLYMER SYSTEMS FOR ANY ADVICE



ALL DIMENSIONS  
SHOWN IN mm

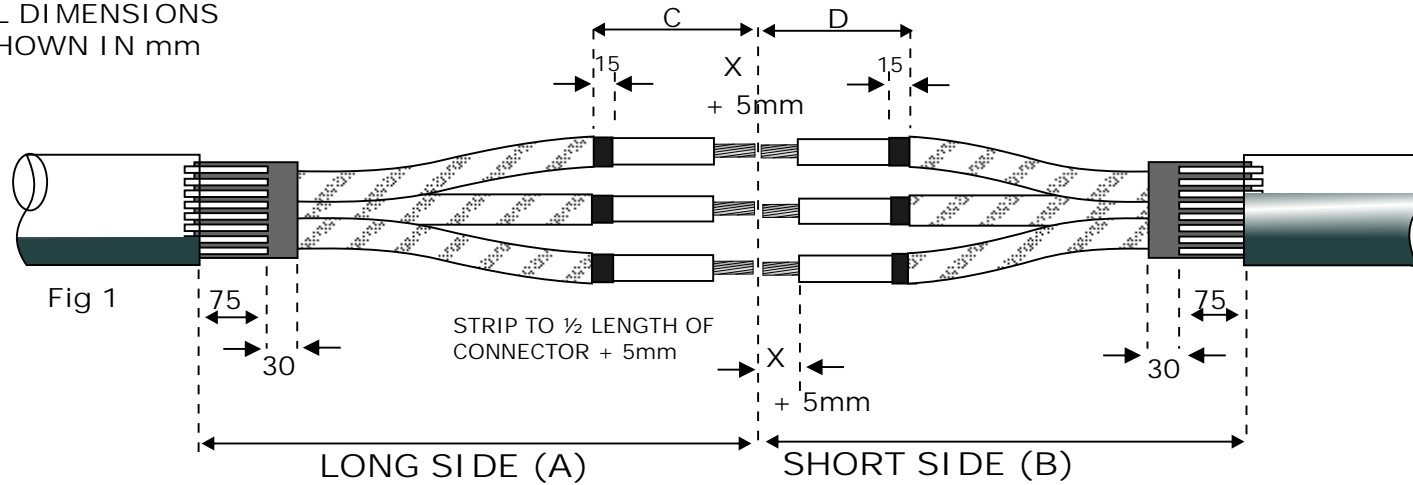

1. Ensure the Cables overlap before preparing to the dimensions above and in accordance with the Table below for Conductor size.
2. Expose Armour to 75mm and Bedding to 30mm.
3. Remove Copper Tape Screens to distance C and D as shown in Table 1.
4. Remove the Black Semi-Conductive layer leaving 15mm exposed. Important: - Do not damage or 'Nick' the Primary Insulation at the Screen cut, an approved Tool can be supplied if required for this purpose.
5. Expose the Conductor to ½ the Connector length + 5mm. Note: - Connector should not exceed maximum length stated in Table 1 below.

SIZE (mm <sup>2</sup> )	A	B	C	D	X	MAX CONNECTOR LENGTH
35-150	1100mm	580mm	220mm	220mm	HALF LENGTH CONNECTOR +5mm	110mm
185-300	1140mm	630mm	240mm	240mm		150mm
400	1240mm	700mm	250mm	250mm		160mm

Table 1

Note:- These Joints are designed for use with HV Compression Ferrules. Please consult if using Mechanical type Connectors.

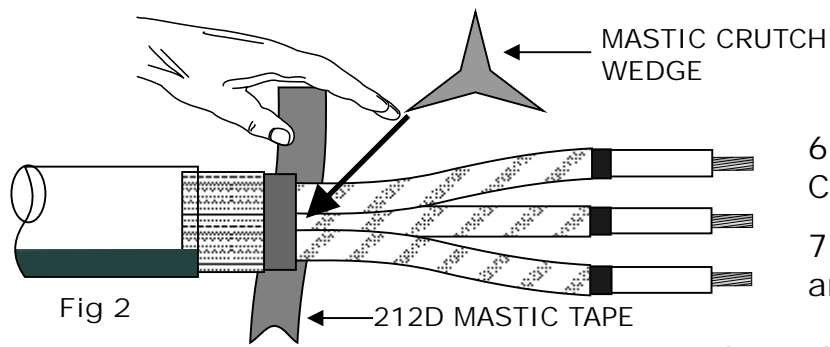

Fig 2

6. De-grease Primary Insulation and remove all traces of Carbon/Semi-Con.

7. Push the Star shaped Mastic Wedge well into each Cable Crutch and wrap the 212D Black Mastic Tape around each Cable Bedding.

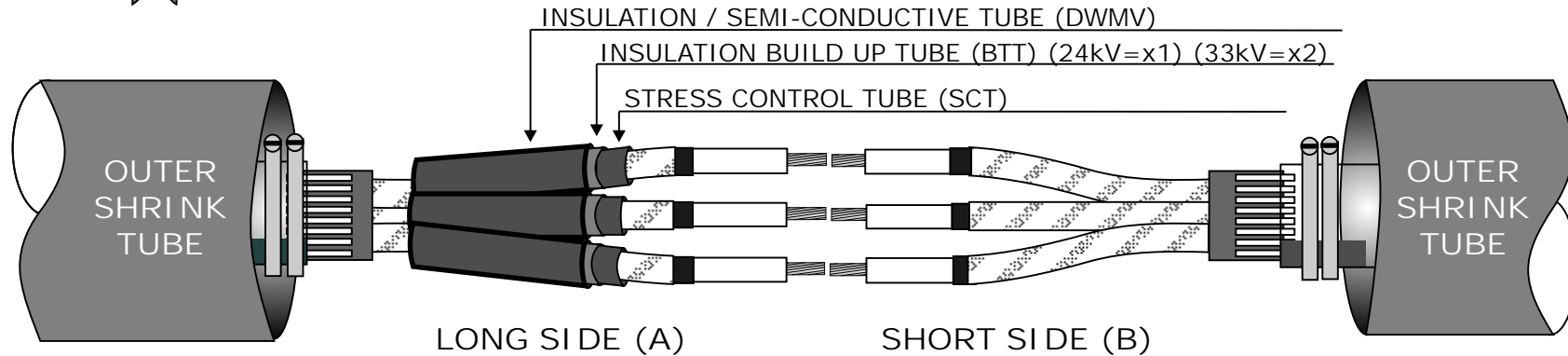

Fig 3

8. Slide the Outer Shrink Sleeve/s, Armour Clamps and Support Rings over one or both of the Cable ends. Position the "Nested" Connector Insulation Tube sets onto the Cores on the Long side of the Joint.

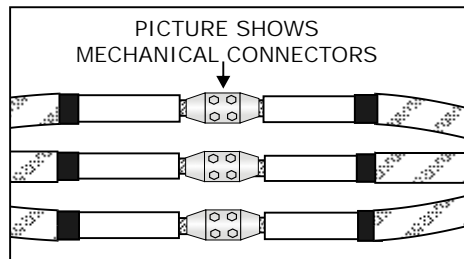

Fig 4

9. Fit the MV type Connectors and crimp with an approved Tool. Ensure they are free from grease and any sharp points.

If fitting Mechanical Connectors, use a Socket or wrench, tighten the bolts until they shear. De-grease Connectors and check for any sharp points which should be removed before proceeding.

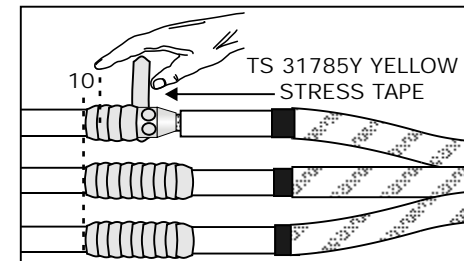

Fig 5

10. Wrap the Yellow Stress Tape (TS 31785Y) around the Connector area with stretch and ½ width overlap. Extend the Tape onto Primary Insulation by 10mm only.

Important:- Fill in the gap between Primary Insulation and Connector. Also fill any voids that the Bolts leave after they have been sheared.

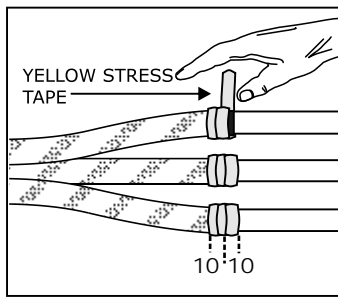

Fig 6

11. Apply one piece of TS 31785Y Yellow Stress Tape with stretch and half width overlap to each Screen end as shown in Fig 6. Overlap the Tape onto the Copper Tape Screen and Primary Insulation by 10mm either side.

ONLY ONE CORE SHOWN FOR CLARITY

HEATSHRINK TUBE REQUIREMENT PER PHASE			
VOLTAGE	SCT	BTT	DWMV
7.2kV	---	---	1
12kV	---	---	1
17.5kV	1	1	1
24kV	1	1	1
36kV	1	2	1

Table 2

SCT = BLACK STRESS CONTROL TUBE

BTT = RED INSULATION TUBE

DWMV = COMBINED INSULATION/CONDUCTIVE TUBE

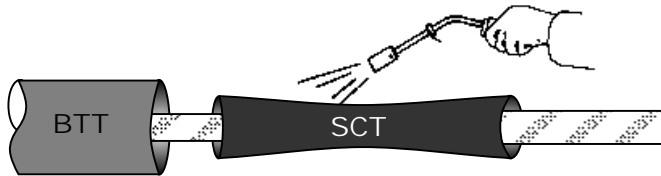

Fig 7

12. Position the Stress Control Tubes (SCT) centrally over the Connectors overlapping the end of Screen points and onto the Copper Tape Screens. With a suitable heat source, shrink all three Tubes at the same time, starting from the centre, working all around the Tubes to one end at a time. Note:- Allow the Tubes to cool before cleaning the surfaces with the Tissues provided. This improves electrical performance.

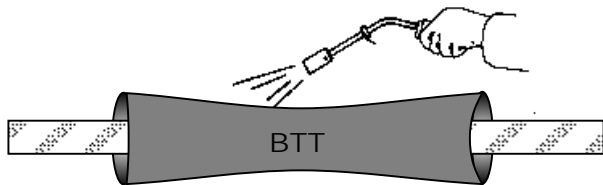

Fig 8

13. Dependant on Voltage class (See Table 2), shrink the required quantity of Red BTT Tubes centrally over the Stress Control Tubes. Two BTT Tubes are required at 36kV, one at 17.5-24kV with none being required at 12kV or below. Finally position the DWMV combined Red Insulation/Semi Conductive Tubes and as before, shrink into place and ensure an even wall thickness is obtained. Note:- Remember to clean each layer with a Cleaning Tissue.

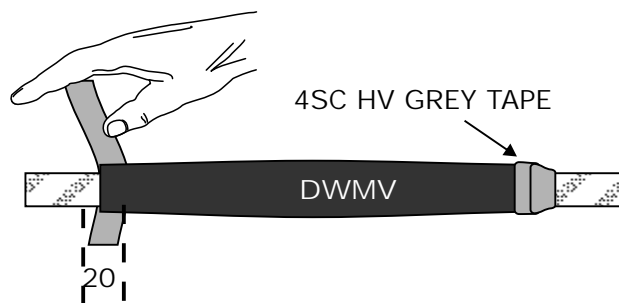

Fig 9

14. Take the six pieces of 4SC HV Grey Mastic Tape and apply to the ends of the DWMV Tubes and Copper Tape Screens by approx 10mm each as shown in Fig 9.

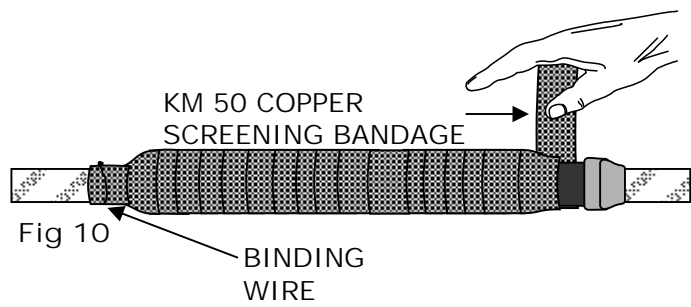

Fig 10

15. Wrap the Copper Screening Bandage (KM 50) with slight overlap on each Core extending onto the Copper Tape Screens by approx 50mm and secure with Binding Wire.

16. Secure the six Earth Braids to the Copper Tape Screens with the Constant Force Springs provided (The Braids will be clamped to the Armours at a later stage).

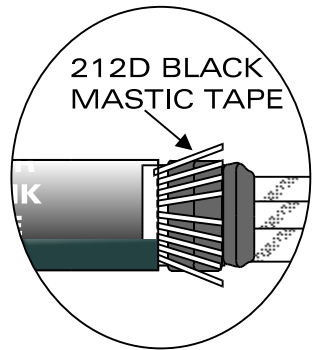

Fig 11

17. Bend back the Armour Wires and apply 212D Black Mastic Tape onto the Bedding directly under the Sheath cut (SWA only).

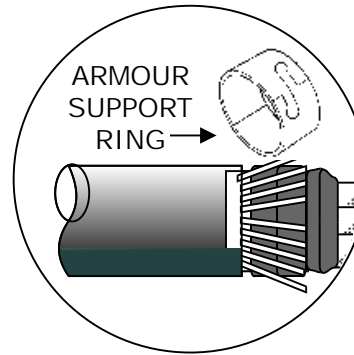

Fig 12

18. Position the Armour Support Rings and fold back the Armour Wires upon them. Note: - Armour Support Rings do not need to be fitted if Cable is Steel Tape Armoured.

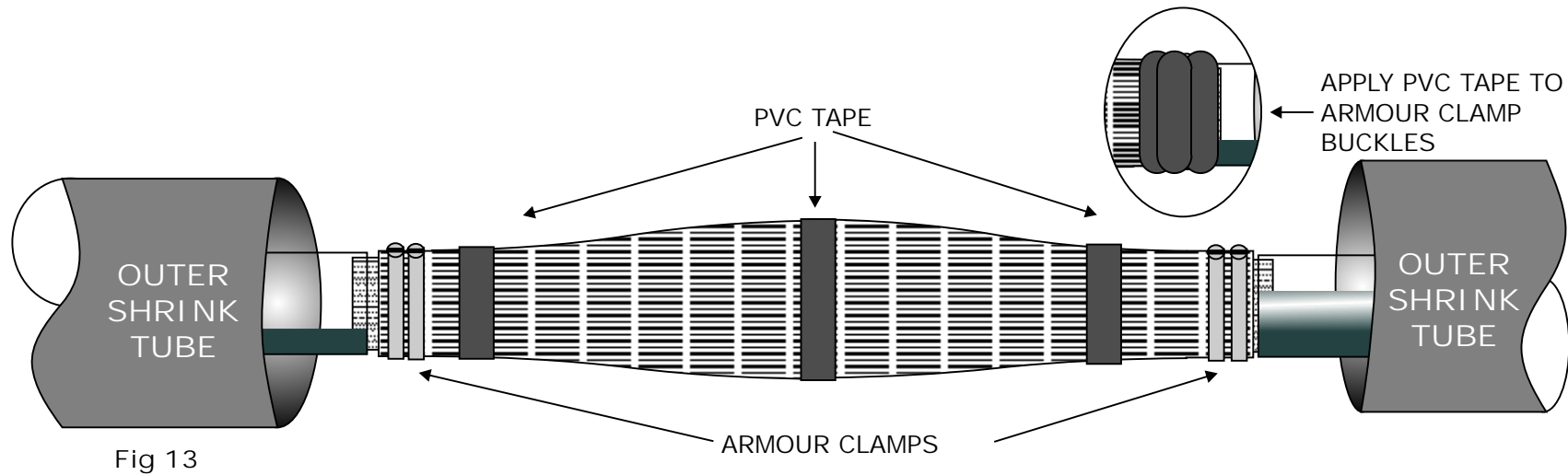

Fig 13

19. Wrap the Armour Protection Cage around the joint gap and use the Pvc Tape to hold it in place. Using the Armour Clamps, clamp the Cage down onto the Armours at each end ensuring that the Flat Earth Braids that are attached to the Copper Tape Screens are also clamped down with it. Tape over the Clamp buckles and Cage fingers with the Pvc Tape.

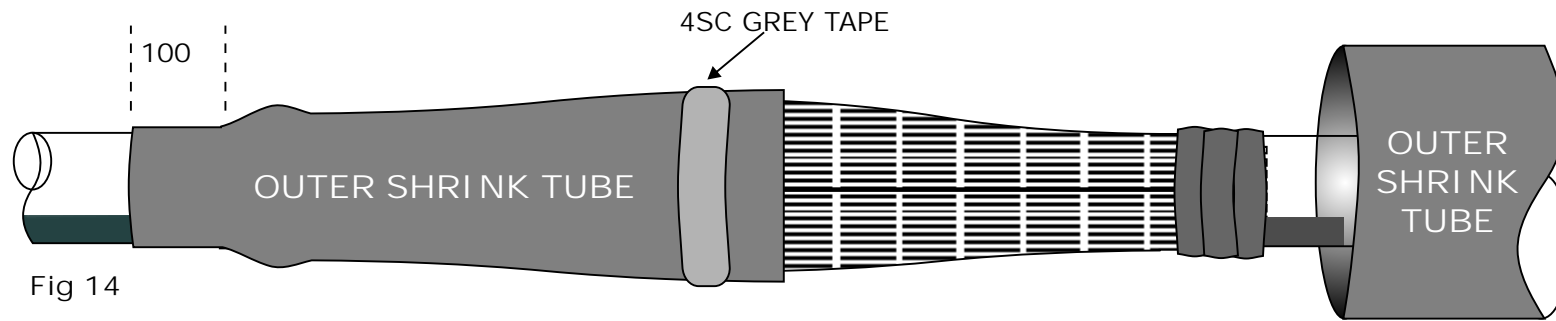

Fig 14

20. Make a mark at 100mm on the Outer Cable Sheath on the Long side of the Joint and position one of the Shrink Tubes to this point. With a suitable heat source, start shrinking from the centre of the Tube to one end at a time. Keep the flame on the move to ensure an even wall thickness. Apply a turn of 4SC Grey Tape approx 75mm in from the end of the Tube as in Fig 14.

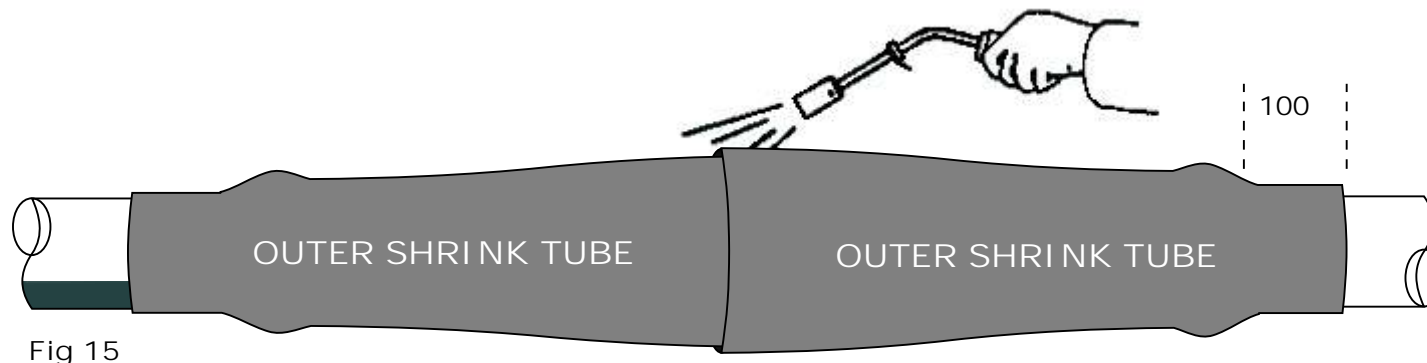

Fig 15

21. Make a mark at 100mm on the Outer Cable Sheath on the Short side of the joint and position the second Tube at this point. Shrink as previous keeping the flame on the move. Once fully shrunk Sealants should be visible at Tube ends.

22. Allow the completed Joint to cool before applying any mechanical strain.

IMPORTANT NOTICE TO PURCHASER: - Sellers and Manufacturere's only obligation shall be to replace such quantity of the product proved to be defective. Neither the Seller nor Manufacturer shall be liable for any injury, loss or damage, direct or consequential, arising out of the use or inability to use the product. Before using, User shall determine the suitability of the product for his or her intended use and User assumes all risk and liability whatsoever in connection therewith.

